

CD WELD STUD TO DIN 32501/440

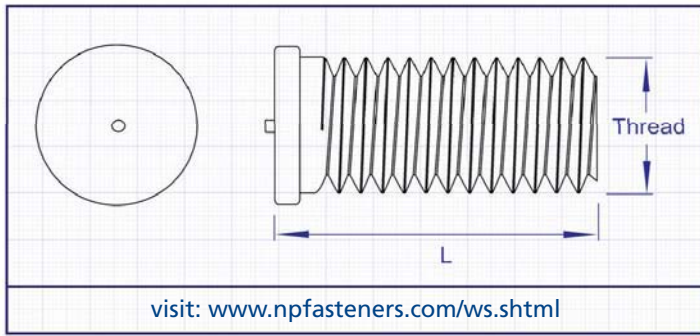

TYPE WS



SPECIFICATION

Thread & Pitch	Available Lengths (L) ± 0.25											
M3 x 0.5	6	8	10	12	16	20	25	30	-	-	-	-
M4 x 0.7	6	8	10	12	16	20	25	30	-	-	-	-
M5 x 0.8	-	8	10	12	16	20	25	30	35	40	-	-
M6 x 1.0	-	-	10	12	16	20	25	30	35	40	45	-
M8 x 1.25	-	-	-	-	16	20	25	30	35	40	45	50

Weld Standoffs & Unthreaded Weld Pins Available To Special Order.

INFORMATION

MATERIALS

Steel, Stainless Steel (A2),
(Aluminium To Special Order).

FINISHES

Steel / Copper Flashed (CP).

PART NUMBER EXAMPLE

Type / Thread / Length / Finish =

WS - M3 - 10 - CP (Weld Stud, M3 x 10mm, Steel, Copper Flash)

WS - M4 - 12 - A2 (Weld Stud, M4 x 12mm, Stainless)

CD WELD SPADE TAG

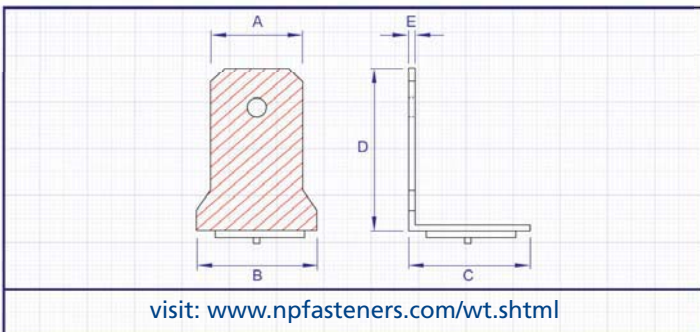

SPECIFICATION

SUITABLE FOR 1/4" RECEPTACLES.

A	B	C	D	E
6.3	8.0	10.0	11.5	0.7

Also available in double sided version (Type D/E).

Other sizes and specials available on request. Please contact our sales office for details.

INFORMATION

MATERIALS

Steel.

FINISHES

Copper Flashed.

PART NUMBER EXAMPLE

Size / Type = 1/4 - Spade Tag Single

For detailed installation guides and performance data visit www.npfasteners.com